

1 **4041 Examination Method of Sealability for Components of Prefilled Syringes**

2 This method consists of examination method for sealability between tip cap/needle shield and
3 barrel and examination method for sealability between plunger stopper and barrel of prefilled
4 syringes.

5 **Method 1: Sealability between tip cap/needle shield and barrel**

6 This method is used to determine the liquid leakage resistance of the fitness between tip
7 cap/needle shield and the needle end or Luer connector of the barrel of a prefilled syringes.

8 **Instruments**

9 Pressure Application Device. Tensile testing machine or pressure device through the
10 application of compressed air.

11 Note: Application of pressure via tensile testing machine(see Fig. 1a) can be used when wall
12 friction can be neglected [when applying the calculating test force according to equation (1), the
13 internal pressure of the syringe can be above 95% of the target pressure.].If wall friction cannot
14 be neglected, preference is given to the test as in Fig.1b, where the pressure is applied on the tip
15 cap/needle shield through the application of compressed air on the filled media.

16 Syringe holder.

17 Plunger stopper and plunger rod.

18 **Sample preparation**

19 The retention time between sample setting and leak tightness test shall be at least 12h.Do not
20 damage or loosen the tip cap/needle shield prior to testing.

21 **Examination Method**

22 Method a: Insert the test sample into the holder (see Fig. 1a). Fill the test sample to
23 between 1/3 and 1/2 of the nominal volume with water. Assemble the plunger stopper and the rod,
24 put them into the barrel. Apply a pressure which is calculated from equation (1) to the rod to make
25 the internal pressure of the barrel 110kPa. And hold the pressure for 5 s. Examine whether the tip
26 cap/needle shield has fallen off and the leakage during and after the test.

27 The correlation between the test force and the cross-sectional area of the syringe that is
28 determined by the nominal inner diameter of the syringe can be calculated using Formula (1) to
29 (3).

$$30 \qquad \qquad \qquad F = p \times A \qquad \qquad \qquad (1)$$

31 and

$$32 \qquad \qquad \qquad A = \frac{\pi}{4} \times d^2 \qquad \qquad \qquad (2)$$

33 follows

$$34 \qquad \qquad \qquad F = p \times \frac{\pi}{4} \times d^2 \times 10^{-3} \qquad \qquad \qquad (3)$$

35 Where

36 F is the test force, N;

37 P is the target internal pressure, kPa (i.e.110kPa);

38

A is the cross sectional area of the syringe barrel, mm^2 ;

39

d is the nominal inner diameter of the syringe barrel, mm .

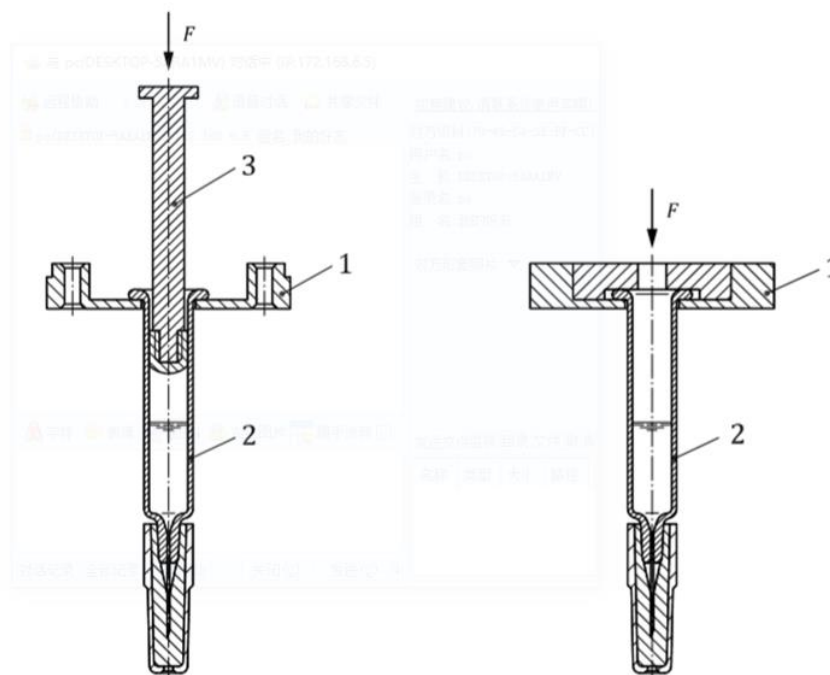

40

a. Pressure applied through plunger rod and plunger stopper

41

42

b. Pressure is applied on the filled media through the application of compressed air

43

Fig. 1 Examples of testing devices for the determination of liquid leak tightness between tip

44

cap/needle shield and the barrel

45

1. Syringe holder; 2. Syringe with tip cap/needle shield; 3. plunger rod and plunger stopper

46

Note: This illustration use a syringe with a needle shield as an example. The testing is equally applicable to syringes with a tip cap.

47

48

Method b: Insert the test sample into the holder(see Fig.1b).Fill the test sample to between 1/3 and 1/2 of the nominal volume with water. Close the end of the syringe, and leave a pressuring passage. Apply a pressure of 110kPa to the syringe and hold the pressure for 5s. Determine whether the tip cap/needle shield has fallen off and the leakage during and after the test.

49

50

51

Method 2: Sealability between plunger stopper and barrel

52

This method is used to examine the liquid leakage resistance of the fitness between the plunger stopper and the barrel of a prefilled syringe when force is applied to the plunger rod.

53

54

Instruments

55

Device for applying a sideways force to the syringe plunger rod, in the range of 0.25N to 3N.

56

Device for generating pressures of 200kPa and 300kPa axial to the barrel and/or plunger rod.

57

58 **Examination Method**

59 Draw into the syringe a volume of water exceeding the nominal capacity of the prefilled
 60 syringe. Expel air and adjust the volume of water in the syringe to the nominal capacity. Connect
 61 the tip/needle tubing to the pressure gage and seal the syringe nozzle. Apply a sideways force to
 62 the push button at right angles to the plunger rod with a force as given in Tab. 1. Orientate the
 63 plunger rod to permit the maximum deflection from the axial position. Apply an axial force to the
 64 syringe so that the pressure given in Table 1 is generated by relative action of the plunger stopper
 65 and barrel. Maintain the pressure for (30_0^{+5}) s. Examine the syringe for liquid leakage past the
 66 plunger stopper, liquid between the ribs is permitted.

67 Tab. 1 Test values for leak tightness between plunger stopper and barrel of the Syringe

Nominal capacity of syringe ml	Side force ($\pm 5\%$) N	Axial pressure ($\pm 5\%$) kPa
$V < 2$	0.25	300
$2 \leq V < 5$	1.0	300
$5 \leq V < 20$	2.0	300
$V \geq 20$	3.0	200

起草单位：山东省医疗器械和药品包装检验研究院

联系电话：0531-82682915

参与单位：江苏省医疗器械检验所、山东威高普瑞医药包装有限公司、山东省药用玻璃有限公司、宁波正力药品包装有限公司、山东永聚医药科技有限公司、肖特药品包装（浙江）有限公司、碧迪医疗器械（上海）有限公司